



## JCT151 Series 12A SCRs

Rev.5.0

### DESCRIPTION:

JCT151 series of silicon controlled rectifiers, with high ability to withstand the shock loading of large current, provide high dv/dt rate with strong resistance to electromagnetic interference. They are especially recommended for use on solid state relay, motorcycle, power charger, T-tools etc. JCT151F/JCT151FP provides insulation voltage rated at 2000V RMS from all three terminals to external heatsink complying with UL standards (File ref: E252906).

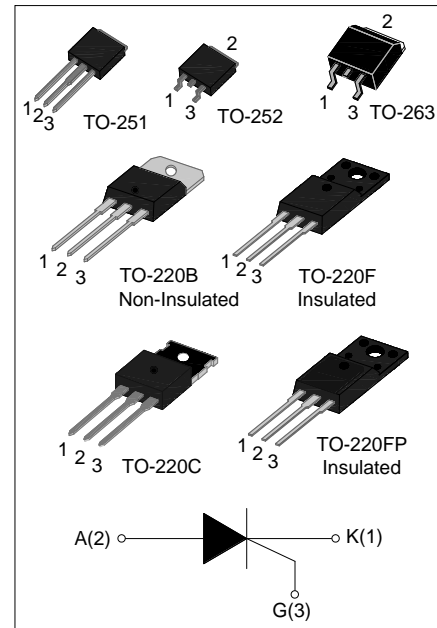

### MAIN FEATURES

Symbol	JCT151-650R	JCT151-800R
$V_{DRM}/V_{RRM}$	650V	800V
$I_{T(RMS)}$	12A	
$I_{GT}$	$\leq 15mA$	

### ABSOLUTE MAXIMUM RATINGS

Parameter		Symbol	Value	Unit
Storage junction temperature range		$T_{stg}$	-40 - 150	$^{\circ}C$
Operating junction temperature range		$T_j$	-40 - 125	$^{\circ}C$
Repetitive peak off-state voltage ( $T_j=25^{\circ}C$ )		$V_{DRM}$	650/800	V
Repetitive peak reverse voltage ( $T_j=25^{\circ}C$ )		$V_{RRM}$	650/800	V
RMS on-state current	TO-251/ TO-252 ( $T_C=98^{\circ}C$ )	$I_{T(RMS)}$	12	A
	TO-220B (Non-Ins)/ TO-220C/ TO-263 ( $T_C=100^{\circ}C$ )			
	TO-220F (Ins) / TO-220FP(Ins) ( $T_C=85^{\circ}C$ )			
Non repetitive surge peak on-state current (tp=10ms)		$I_{TSM}$	120	A

I <sup>2</sup> t value for fusing (tp=10ms)	I <sup>2</sup> t	72	A <sup>2</sup> s
Repetitive rate of rise of on-state current (I <sub>G</sub> =2×I <sub>GT</sub> )	dI <sub>T</sub> /dt	50	A/μs
Peak gate current	I <sub>GM</sub>	2	A
Peak gate power	P <sub>GM</sub>	5	W
Average gate power dissipation	P <sub>G(AV)</sub>	0.5	W

**ELECTRICAL CHARACTERISTICS** (T<sub>j</sub>=25°C unless otherwise specified)

Symbol	Test Condition	Value			Unit
		MIN.	TYP.	MAX.	
I <sub>GT</sub>	V <sub>D</sub> =12V R <sub>L</sub> =33Ω	-	4	15	mA
V <sub>GT</sub>		-	0.75	1.5	V
V <sub>GD</sub>	V <sub>D</sub> =V <sub>DRM</sub> T <sub>j</sub> =125°C R <sub>L</sub> =3.3KΩ	0.2	-	-	V
I <sub>L</sub>	I <sub>G</sub> =1.2I <sub>GT</sub>	-	12	40	mA
I <sub>H</sub>	I <sub>T</sub> =500mA	-	12	30	mA
dV/dt	V <sub>D</sub> =2/3V <sub>DRM</sub> Gate Open T <sub>j</sub> =125°C	200	400	-	V/μs

**STATIC CHARACTERISTICS**

Symbol	Parameter		Value(MAX)	Unit
V <sub>TM</sub>	I <sub>TM</sub> =23A tp=380μs	T <sub>j</sub> =25°C	1.7	V
I <sub>DRM</sub>	V <sub>D</sub> =V <sub>DRM</sub> V <sub>R</sub> =V <sub>RDM</sub>	T <sub>j</sub> =25°C	10	μA
I <sub>RDM</sub>		T <sub>j</sub> =125°C	1	mA

**THERMAL RESISTANCES**

Symbol	Parameter		Value	Unit
R <sub>th(j-mb)</sub>	Junction to mounting base	TO-251/ TO-252	2.0	°C/W
		TO-220B (Non-Ins)/ TO-220C	1.7	
		TO-220F (Ins)/ TO-220FP (Ins)	4.5	
		TO-263	1.5	

**ORDERING INFORMATION**

JieJie Microelectronics Co.,Ltd	J	CT	151	B	-650R
	SCRs		IT(RMS):12A	650R: $V_{DRM} / V_{RRM} \geq 650V$ 800R: $V_{DRM} / V_{RRM} \geq 800V$	
H:TO-251 K:TO-252 E:TO-263 F:TO-220F(Ins) FP:TO-220FP(Ins) B:TO-220B(Non-Ins) C:TO-220C					

**PACKAGE MECHANICAL DATA**

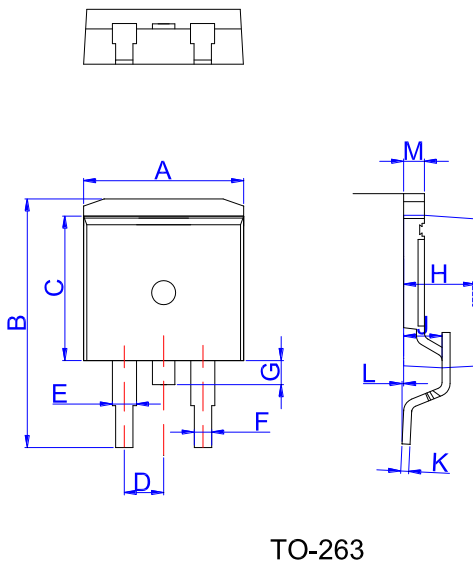

Ref.	Dimensions					
	Millimeters			Inches		
	Min.	Typ.	Max.	Min.	Typ.	Max.
A	9.90		10.20	0.390		0.402
B	14.70		15.80	0.579		0.622
C	9.4		9.6	0.37		0.378
D		2.54			0.100	
E	1.20		1.40	0.047		0.055
F	0.75		0.85	0.029		0.033
G			1.75			0.069
H	4.40		4.70	0.173		0.185
J	2.30		2.70	0.091		0.106
K	0.38		0.55	0.015		0.022
L	0	0.10	0.25	0	0.004	0.010
M	1.25		1.35	0.049		0.053

PACKAGE MECHANICAL DATA

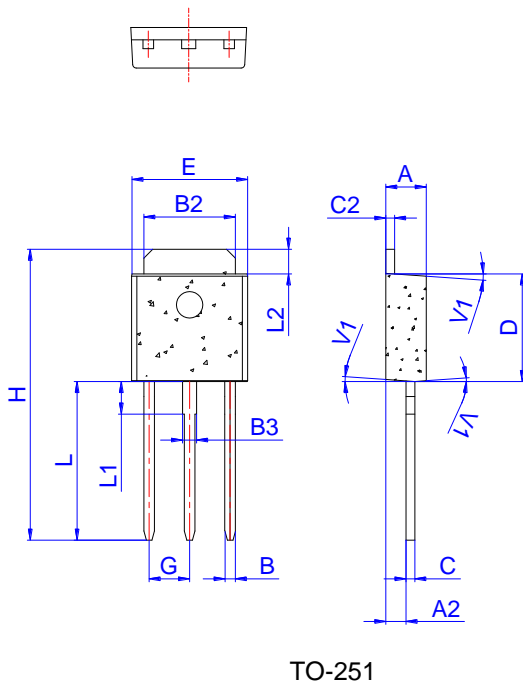

Ref.	Dimensions					
	Millimeters			Inches		
	Min.	Typ.	Max.	Min.	Typ.	Max.
A	2.20		2.40	0.086		0.095
A2	0.90		1.20	0.035		0.047
B	0.55		0.65	0.022		0.026
B2	5.10		5.40	0.200		0.213
B3	0.76		0.85	0.030		0.033
C	0.45		0.62	0.018		0.024
C2	0.48		0.62	0.019		0.024
D	6.00		6.20	0.236		0.244
E	6.40		6.70	0.252		0.264
G		2.30			0.091	
H	16.0		17.0	0.630		0.669
L	8.90		9.40	0.350		0.370
L1	1.80		1.90	0.071		0.075
L2	1.37		1.50	0.054		0.059
V1		4°			4°	

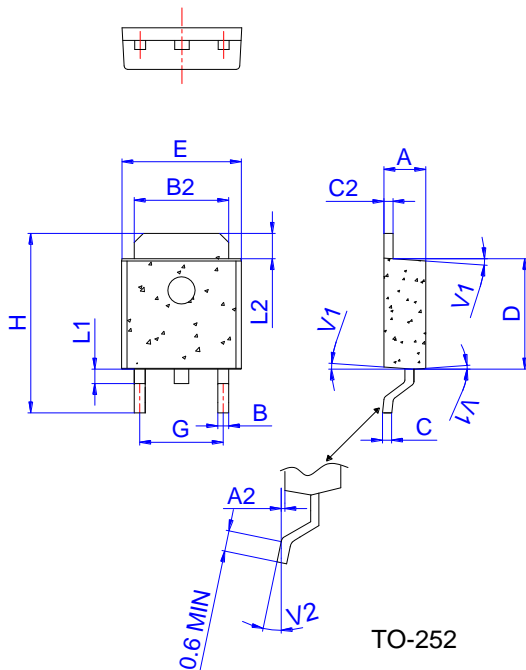

Ref.	Dimensions					
	Millimeters			Inches		
	Min.	Typ.	Max.	Min.	Typ.	Max.
A	2.20		2.40	0.086		0.095
A2	0.03		0.23	0.001		0.009
B	0.55		0.65	0.022		0.026
B2	5.10		5.40	0.200		0.213
C	0.45		0.62	0.018		0.024
C2	0.48		0.62	0.019		0.024
D	6.00		6.20	0.236		0.244
E	6.40		6.70	0.252		0.264
G	4.40		4.70	0.173		0.185
H	9.35		10.6	0.368		0.417
L1	1.30		1.70	0.051		0.067
L2	1.37		1.50	0.054		0.059
V1		4°			4°	
V2	0°		8°	0°		8°

PACKAGE MECHANICAL DATA

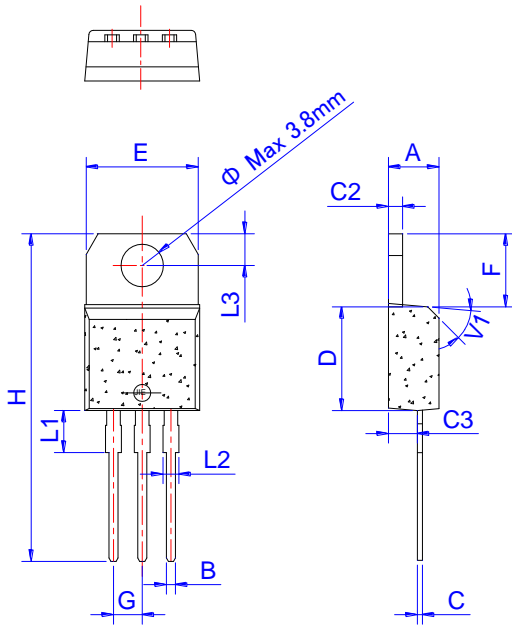

Ref.	Dimensions					
	Millimeters			Inches		
	Min.	Typ.	Max.	Min.	Typ.	Max.
A	4.40		4.60	0.173		0.181
B	0.61		0.88	0.024		0.035
C	0.46		0.70	0.018		0.028
C2	1.21		1.32	0.048		0.052
C3	2.40		2.72	0.094		0.107
D	8.60		9.70	0.339		0.382
E	9.60		10.4	0.378		0.409
F	6.20		6.60	0.244		0.260
G		2.54			0.1	
H	28.0		29.8	1.102		1.173
L1		3.75			0.148	
L2	1.14		1.70	0.045		0.067
L3	2.65		2.95	0.104		0.116
V1		45°			45°	

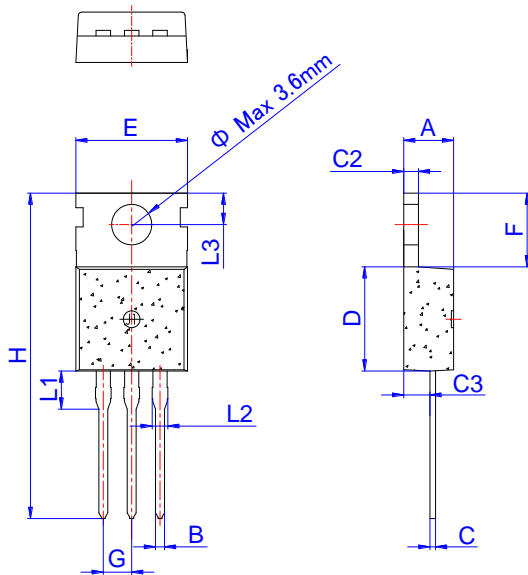

Ref.	Dimensions					
	Millimeters			Inches		
	Min.	Typ.	Max.	Min.	Typ.	Max.
A	4.40		4.60	0.173		0.181
B	0.70		0.90	0.028		0.035
C	0.45		0.60	0.018		0.024
C2	1.23		1.32	0.048		0.052
C3	2.20		2.60	0.087		0.102
D	8.90		9.90	0.350		0.390
E	9.90		10.3	0.390		0.406
F	6.30		6.90	0.248		0.272
G		2.54			0.1	
H	28.0		29.8	1.102		1.173
L1		3.39			0.133	
L2	1.14		1.70	0.045		0.067
L3	2.65		2.95	0.104		0.116
Φ		3.6			0.142	

PACKAGE MECHANICAL DATA

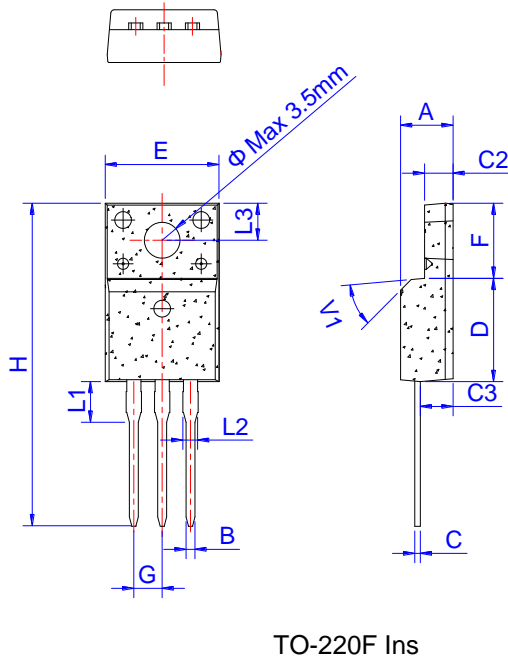

Ref.	Dimensions					
	Millimeters			Inches		
	Min.	Typ.	Max.	Min.	Typ.	Max.
A	4.40		4.80	0.173		0.189
B	0.74	0.80	0.83	0.029	0.031	0.033
C	0.48		0.75	0.019		0.030
C2	2.40		2.70	0.094		0.106
C3	2.60		3.00	0.102		0.118
D	8.80		9.30	0.346		0.366
E	9.70		10.3	0.382		0.406
F	6.40		7.00	0.252		0.276
G		2.54			0.1	
H	28.0		29.8	1.102		1.173
L1		3.63			0.143	
L2	1.14		1.70	0.045		0.067
L3		3.30			0.130	
V1		45°			45°	

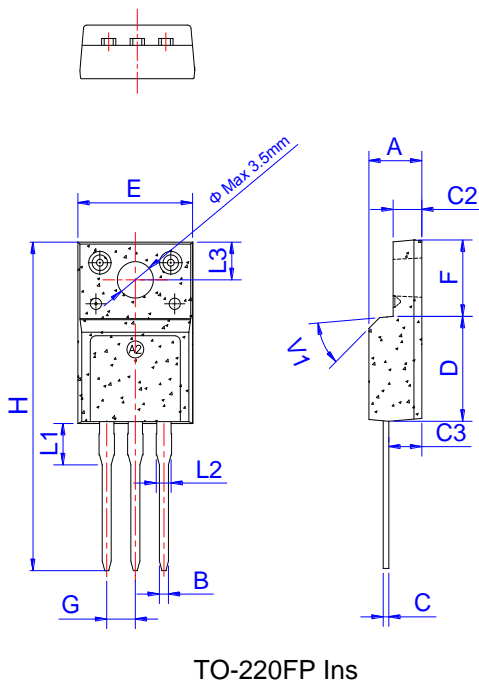

Ref.	Dimensions					
	Millimeters			Inches		
	Min.	Typ.	Max.	Min.	Typ.	Max.
A	4.50		4.90	0.177		0.193
B	0.74	0.80	0.83	0.029	0.031	0.033
C	0.47		0.65	0.019		0.026
C2	2.45		2.75	0.096		0.108
C3	2.60		3.00	0.102		0.118
D	8.80		9.30	0.346		0.366
E	9.80		10.4	0.386		0.410
F	6.40		6.80	0.252		0.268
G		2.54			0.1	
H	28.0		29.8	1.102		1.173
L1		3.63			0.143	
L2	1.14		1.70	0.045		0.067
L3		3.30			0.130	
V1		45°			45°	

**FIG.1:** Maximum power dissipation versus RMS on-state current

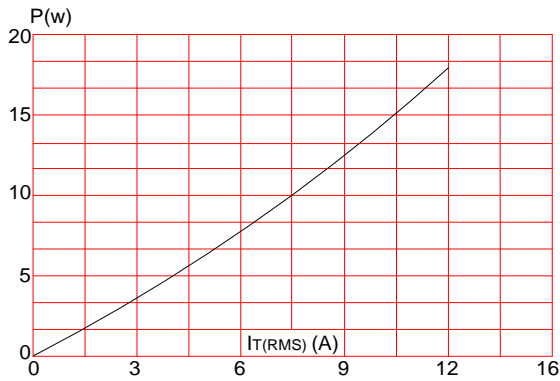

**FIG.3:** Surge peak on-state current versus number of cycles

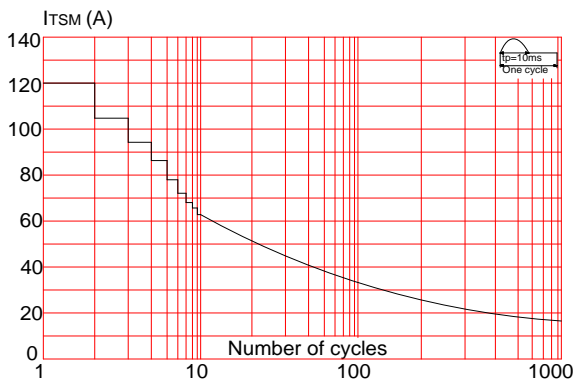

**FIG.5:** Non-repetitive surge peak on-state current for a sinusoidal pulse with width  $t_p < 10\text{ms}$ , and corresponding value of  $I^2t$  ( $di/dt < 50\text{A}/\mu\text{s}$ )

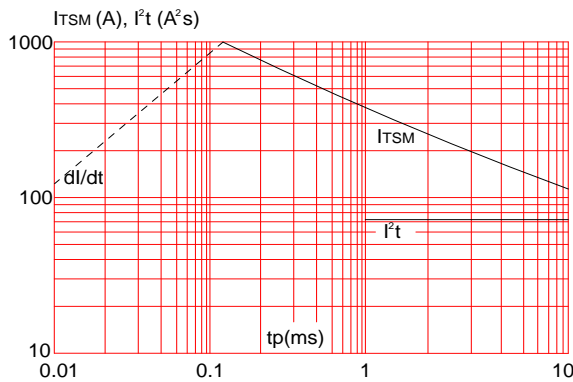

**FIG.2:** RMS on-state current versus case temperature

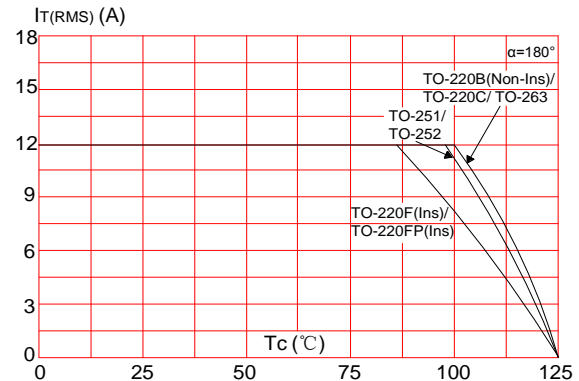

**FIG.4:** On-state characteristics (maximum values)

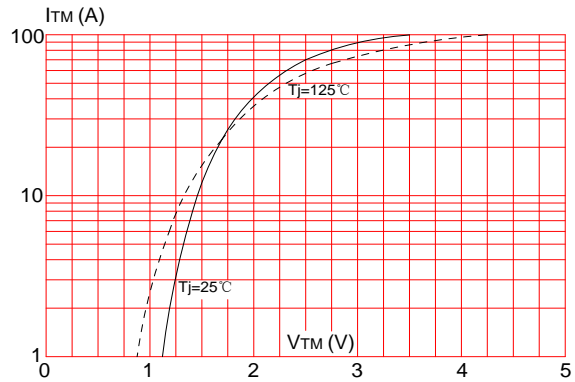

**FIG.6:** Relative variations of gate trigger current, holding current and latching current versus junction temperature

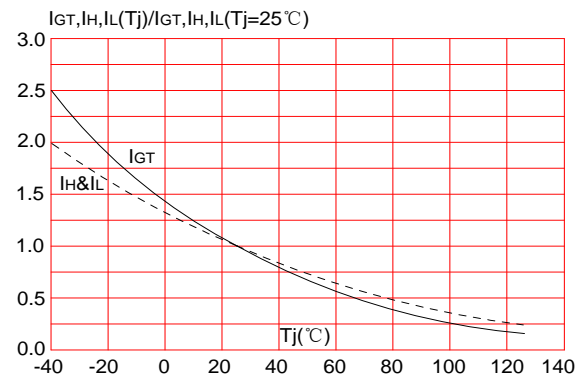

Information furnished in this document is believed to be accurate and reliable.

However, Jiangsu JieJie Microelectronics Co.,Ltd assumes no responsibility for the consequences of use without consideration for such information nor use beyond it. Information mentioned in this document is subject to change without notice, apart from that when an agreement is signed, Jiangsu JieJie complies with the agreement. Products and information provided in this document have no infringement of patents. Jiangsu JieJie assumes no responsibility for any infringement of other rights of third parties which may result from the use of such products and information. This document is the fifth version which is made in 6-Aug.-2015. This document supersedes and replaces all information previously supplied.

 is a registered trademark of Jiangsu JieJie Microelectronics Co.,Ltd.

Copyright ©2015 Jiangsu JieJie Microelectronics Co.,Ltd. Printed All rights reserved.