



吉安市木林森电子科技有限公司
JI AN M. L. S ELECTRONICS CO., LTD

PRODUCT SPECIFICATION

ITEM NO.: F3AB4UC10-A

NAME: Φ3 long size white to blue

CUSTOMER: _____

DEPARTMENT: ENGINEERING DEPARTMENT

EDITION: A/0



COMPANY ADDRESS: JUNSHAN ROAD , HIGH TECHNOLOGY DEVELOPMENT
DISTRICT , JI'AN CITY , JIANGXI PROVINCE
TEL: 0796-8402995 FAX: 0796-8402995

WEB: <http://www.jaml.com/>

最具规模的
LED生产厂家



PRODUCT SPECIFICATION

ITME NO.: F3AB4UC10-A

Page

1/3

Package Dimensions:

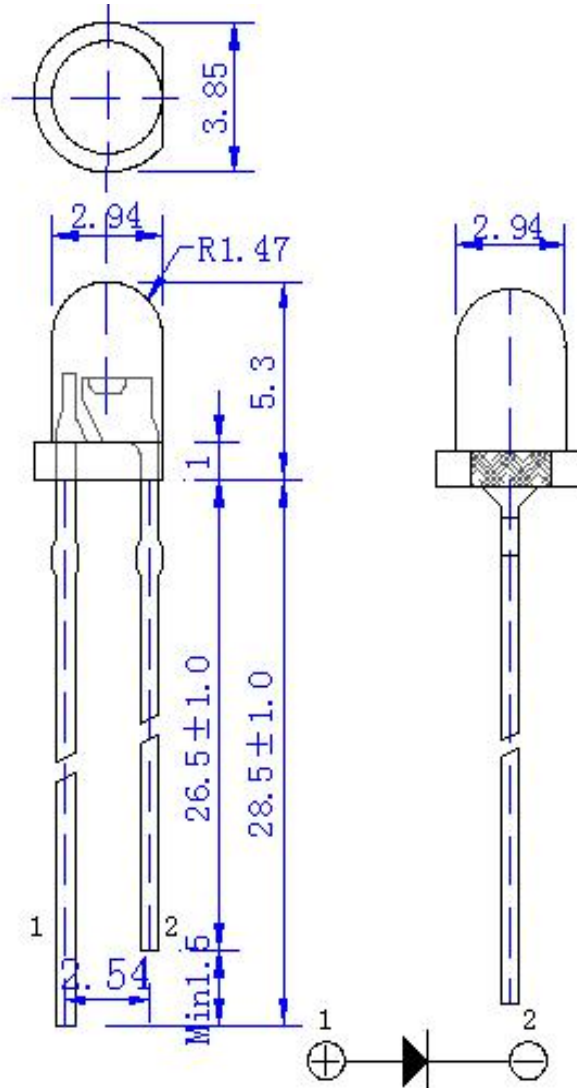

Lens	Material	Emitting Color
water clear	InGaAlP	blue

Notes:

1. Unit: mm

2. Tolerance does not indicate if it is not over plus or minus 0.25 mm or 0.010 in.

3. Surplus colloid not up to 1.0mm

4. Without prior notice for specification changes .



Maximum Parameter at TA=25 °C

parameter	absolute rating	unit
pulse current	60	mA
forward direct current	20	mA
backward voltage	6	V
work temperature	-40°C to+100°C	
preservation temperature	-40°C to+100°C	
welding temperature	260°C for 3 seconds	

Electrooptical Characteristic at TA=25 °C

parameter	symbol	min	standard	max	unit	test addition
luminous intensity	I _v	1000		4000	mcd	IF=20mA
Lighting Angle	2θ _{1/2}		30		deg	IF=20mA
peak wavelength	λ _p	455		465	nm	IF=20mA
forward voltage	V _F	2.65		3.6	V	IF=20mA
Reverse current	I _R			3	μA	VR=5V

Remark:

- 1、 This brightness is according to the human eye luminous intensity of the induction curve of the simulation which is in line with CIE (International Optical Committee Organization)
- 2、 light emitting angle of measurement test data comes from half luminance
3. Brightness error is not over plus or minus 15%



Operation instruction

1. Use

This LED can be used for ordinary electronic equipment, such as office equipment, communications equipment, house decoration, if the LED used in some circumstances requiring high reliability, such as air transport, traffic control and medical equipment, it must be used according to the provided reference sales instruction

2. Storage

LED's maximum storage temperature not exceed 40 degrees C ,and relative humidity not exceed 70%. We suggested that the LED date in the original container was not more than three months .If you need to lengthen the storage time, please put it into the oven, and add desiccant, or filled in nitrogen.

3. Clean

When use the chemicals to clean colloid, we must be especially careful, because some chemicals on the colloid surface will cause damage and discoloration, such as trichlorethylene, acetone. We can ethanol wipe, dip at the normal temperature and not more than three minutes.

4. Pin assembly

- (1) It must be 2 mm from the colloid when bend bracket.
- (2) Stent placement must be done by the fixture or done by professionals.
- (3) Stent placement must be completed prior to welding..
- (4) Stenting need to ensure that the pin spacing is the same as circuit board.
- (5) Welding must be carried out at normal temperature and normal LED soldered to the PCB should be avoided to exert mechanical pressure on the LED pin .

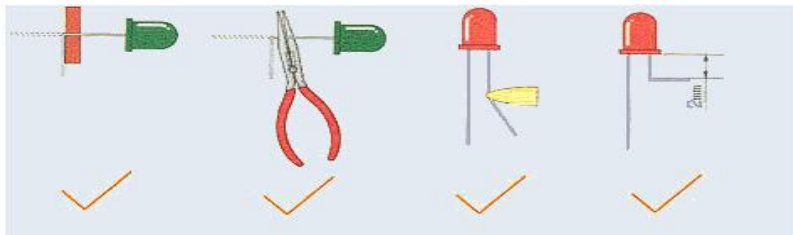

5. Welding

When welding, it is necessary to carry out in colloidal bottom of the 2mm and you should try to avoid dipping LED colloid When finished the welding , you should avoid the pin plus external or shaking LED colloid.

Recommended Welding Conditions

solder with the soldering bit		wave-soldering	
Temperature	260°C Max	Pre-heat	100°C Max
Welding time	5 sec.Max	Pre-heat time	60sec.Max
	(one time only)	Solder wave	260°C Max
		Soldering time	10sec.Max

Too high welding temperature and long soldering can cause the LED to the deformation and invalidation

6. Drive mode

LED current drive mode

If the LED is more satellites in parallel, it is recommended to use line A and plus a current limiting resistor in every single LED in order to ensure consistency of LED brightness.

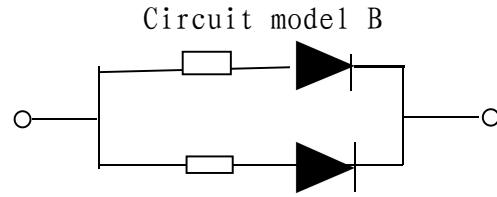
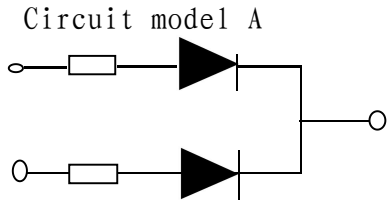

7. Electrostatic protection

Static and current sharp rise will harm the LED . when use the InGaN series product , pls use antistatic devices, such as shelter belts and gloves

Note: use the human body discharge mode HBM <1000V; machine model <100V.